

# **Illumipanel 28 IP Optic RGB**

## **User Manual**

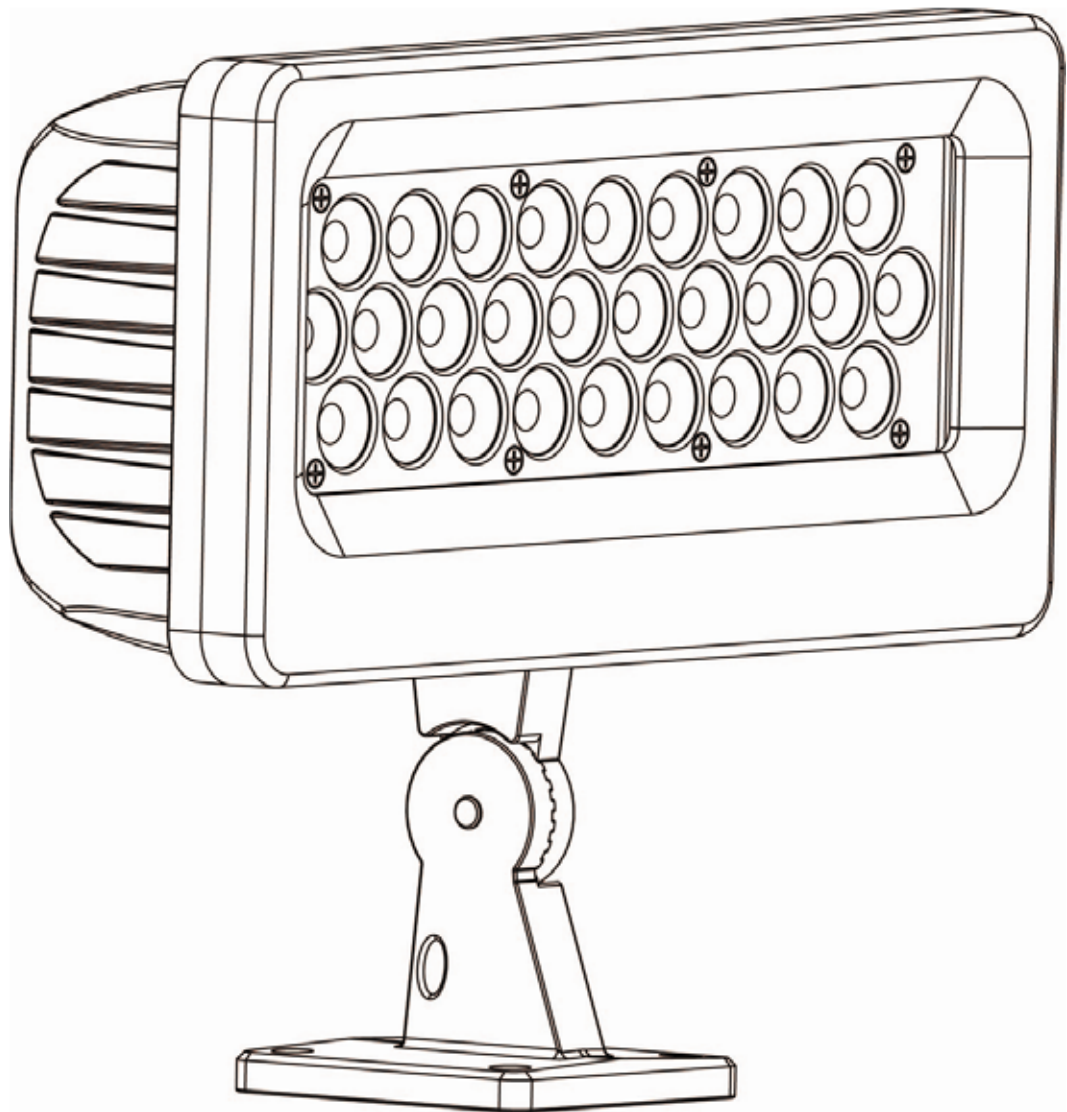

**ILUMINARC®**

## Edition Notes

The Ilumipanel 28 IP Optic RGB User Manual Rev. .04d covers the description, safety precautions, installation, programming, operation, and maintenance of the Ilumipanel 28 IP Optic RGB ILUMINARC® released this edition of the Ilumipanel 28 IP Optic RGB User Manual Rev. 05 in July 2011.

## Trademarks

The ILUMINARC® logo, the ILUMINARC® name and all other trademarks in this document related to services or products by ILUMINARC® are trademarks owned or licensed by ILUMINARC®, its affiliates or subsidiaries. Any other product names, logos, brands, company names or trademarks featured or referred to within this document are the property of their respective trademark holders.

## Copyright Notice

The entire content of this document, except where applicable and unless otherwise noted, is solely owned by ILUMINARC®, a wholly owned trademark of CHAUVET & Sons Inc.

© Copyright 2011 ILUMINARC®

All rights reserved

Electronically published by ILUMINARC® in the United States of America

## Manual Usage

ILUMINARC® authorizes its customers to download and print this manual for professional information purposes only. ILUMINARC® expressly prohibits the usage, copy, storage, distribution, modification, or printing of this manual or its content for any other purpose without its written consent.

## Document Printing

For better results, print this document in color, on letter size paper (8.5 x 11 inches), double sided. If using A4 paper (210 x 297 mm), configure your printer to scale the content of this document to A4 paper.

## Intended Audience

Any person in charge of installing, operating and/or maintaining the Ilumipanel 28 IP Optic RGB should read the Guide that shipped with it and this manual in their entirety before installing, operating or maintaining this product.

## Disclaimer

ILUMINARC® believes that the information contained in this manual is accurate in all respects. However, ILUMINARC® assumes no responsibility for any error or omissions in this document. ILUMINARC® reserves the right to revise this document and to make changes from time to time in the content hereof without obligation of ILUMINARC® to notify any person or company of such revision or changes. This does not constitute in any way a commitment by ILUMINARC® to make such changes. ILUMINARC® may issue a revision of this manual or a new edition of it to incorporate such changes.

## ILUMINARC® Publications Hot Line

If you have any comments about the accuracy of this document or general suggestions regarding how we can improve it, please call us at (954) 923-3680. You can download the latest versions of all ILUMINARC® products' manuals from [www.iluminarc.com](http://www.iluminarc.com).

## Document Revision

The Ilumipanel 28 IP Optic RGB User Manual Rev. 05 supersedes all previous versions of this manual. Please discard any older versions of this manual you may have, whether in printed or electronic format, and replace them with this version.

# Table of Contents

<b>1. BEFORE YOU BEGIN</b> .....	<b>IV</b>
WHAT IS INCLUDED.....	1
UNPACKING INSTRUCTIONS.....	1
AC POWER.....	1
<i>Power Distribution</i> .....	1
SAFETY INSTRUCTIONS.....	2
<b>2. INTRODUCTION</b> .....	<b>3</b>
DMX CHANNEL SUMMARY.....	3
PRODUCT OVERVIEW.....	4
<b>PRODUCT DIMENSIONS</b> .....	<b>5</b>
<b>3. SETUP</b> .....	<b>6</b>
FIXTURE LINKING.....	6
DATA CABLING.....	6
<i>DMX Data Cable</i> .....	6
<i>Signal Distribution</i> .....	6
WIRING DIAGRAM.....	7
MOUNTING.....	7
<i>Orientation</i> .....	7
<i>Rigging</i> .....	7
<b>4. OPERATING INSTRUCTIONS</b> .....	<b>8</b>
MENU MAP (ILUMICODE-REMOTE ADDRESSER).....	8
<i>Operation</i> .....	8
DMX CHANNEL VALUES.....	9
<i>ARC FULL</i> .....	9
<i>ARC 1</i> .....	10
<i>ARC 1+D</i> .....	10
<i>Solid</i> .....	10
CONTACT US.....	10
<b>5. APPENDIX</b> .....	<b>11</b>
DMX PRIMER.....	11
<i>Setting the Starting Address</i> .....	11
GENERAL MAINTENANCE.....	12
RETURNS PROCEDURE.....	12
CLAIMS.....	12
TECHNICAL SPECIFICATIONS.....	13

**Page left intentionally blank.**

# 1. BEFORE YOU BEGIN

## What is Included

- 1 x Ilumipanel 28 IP Optic RGB
- 1 x Warranty Card
- 1 x User Manual

## Unpacking Instructions

Immediately upon receiving a fixture, carefully unpack the carton, check the contents to ensure that all parts are present, and have been received in good condition. Notify the shipper immediately and retain packing material for inspection if any parts appear damaged from shipping or the carton itself shows signs of mishandling. Save the carton and all packing materials. In the event that a fixture must be returned to the factory, it is important that the fixture be returned in the original factory box and packaging .

## AC Power

This fixture has an auto-ranging power supply that can accommodate a wide range of input voltages. The only thing necessary to do before powering on the unit is to make sure the line voltage you are applying is within the range of accepted voltages. This fixture will accommodate between 100V and 240V AC 50-60 Hz. All fixtures must be powered directly off a switched circuit and cannot be run off a rheostat (variable resistor) or dimmer circuit, even if the rheostat or dimmer channel is used solely for a 0% to 100% switch.

**Warning!** *Verify that the voltage input on your unit matches the line voltage applied. Damage to your fixture may result if the line voltage applied does not match the voltage indicated on the voltage input. All fixtures must be connected to circuits with a suitable Earth Ground.*

## Power Distribution

Connect the bare-ended power cable from the product to a power distribution box as indicated below.

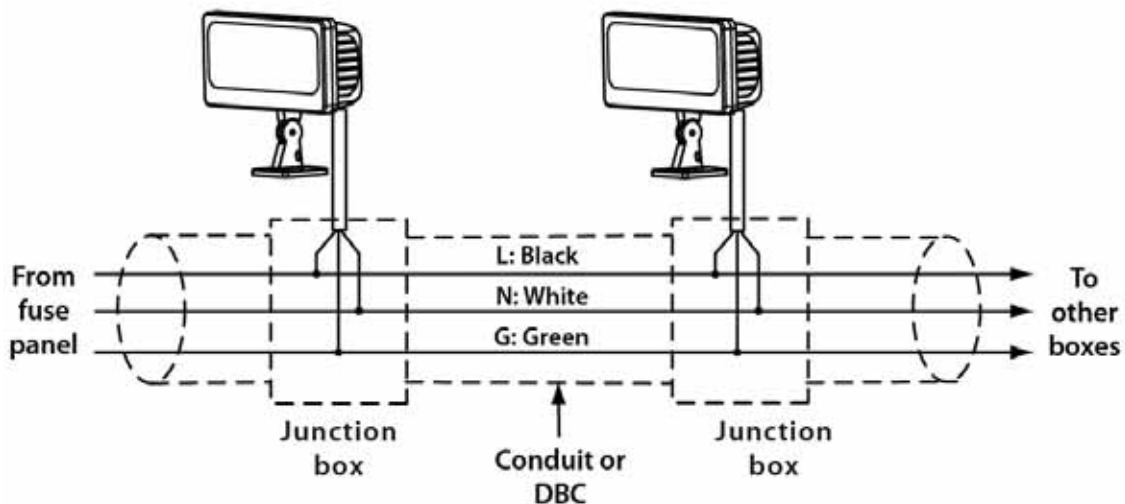

## Safety Instructions



Please read these instructions carefully, which includes important information about the installation, usage and maintenance of this product.

- Please keep this User Guide for future consultation. If you sell the unit to another user, be sure that they also receive this instruction booklet.
- Always make sure that you are connecting to the proper voltage, and that the line voltage you are connecting to is not higher than that stated on the decal or rear panel of the fixture.
- Secure fixture to fastening device using a safety chain.
- Maximum ambient temperature (Ta) is 104°F (40°C). Do not operate fixture at temperatures higher than this.
- In the event of a serious operating problem, stop using the unit immediately. Never try to repair the unit by yourself. Repairs carried out by unskilled people can lead to damage or malfunction. Please contact the nearest authorized technical assistance center. Always use the same type spare parts.
- Never connect the device to a dimmer pack.
- Make sure the power cord is never crimped or damaged.
- Never disconnect the power cord by pulling or tugging on the cord.
- Avoid direct eye exposure to the light source while it is on.

**Caution!** *There are no user serviceable parts inside the unit. Do not open the housing or attempt any repairs yourself. In the unlikely event your unit may require service, please contact ILUMINARC™ at: 954.923.3680 (ext.4000).*

**Caution!** *After prolonged periods of operation, the fixture chassis may reach high temperatures. Use caution when handling this fixture.*

## 2. INTRODUCTION

### DMX Channel Summary

The Ilumipanel 28 IP Optic RGB has multiple personalities, which can be changed using the Ilumicode remote addresser. There are 4 personalities.

#### ARC FULL

CHANNEL	FUNCTION
1	Dimmer
2	Red
3	Green
4	Blue
5	Color Macro
6	Strobe
7	Dimming Speed

#### ARC 1

CHANNEL	FUNCTION
1	Red
2	Green
3	Blue

#### ARC 1+D

CHANNEL	FUNCTION
1	Dimmer
2	Red
3	Green
4	Blue

#### Solid

CHANNEL	FUNCTION
1	Dimmer

## Product Overview

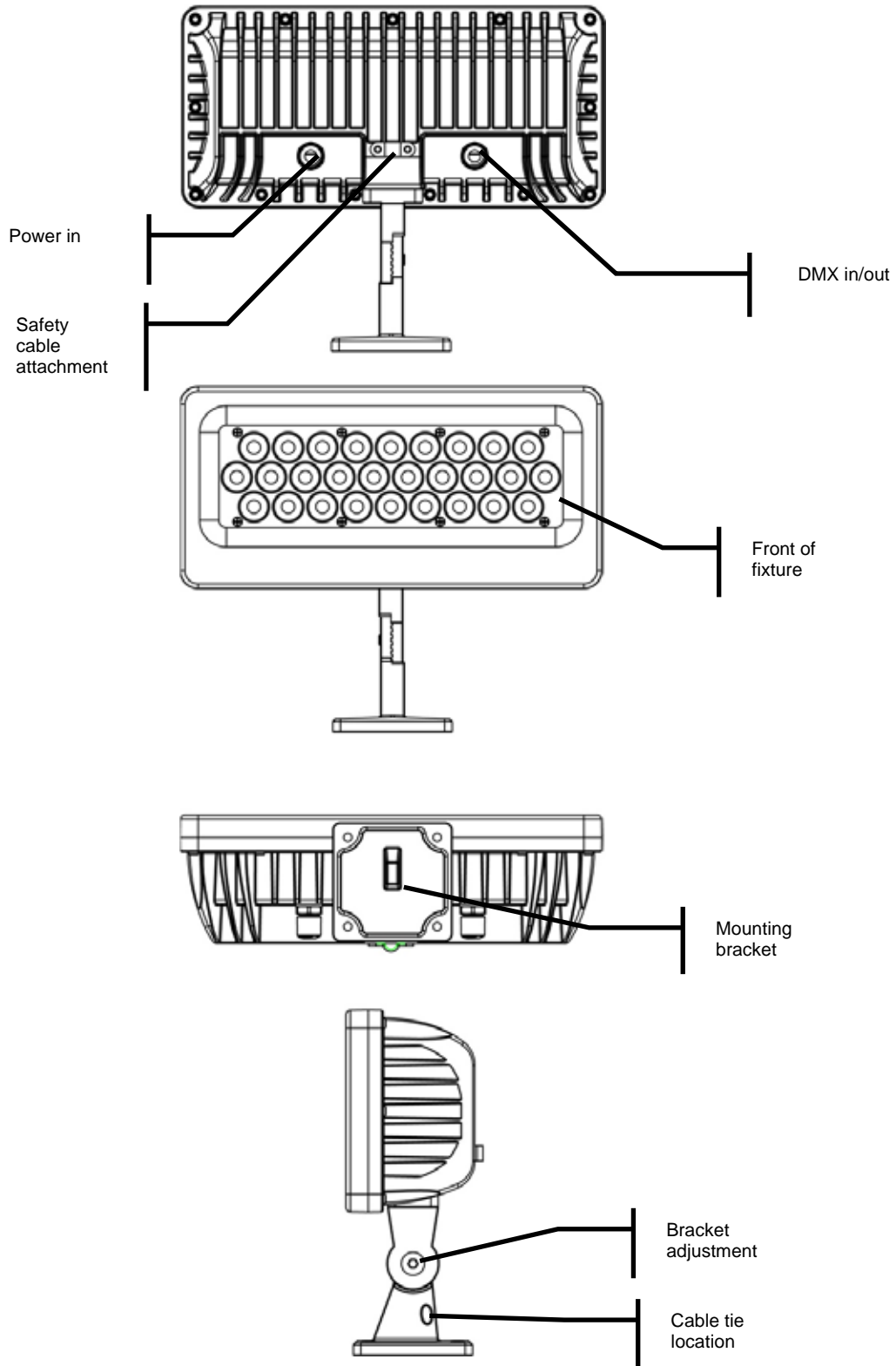

### Product Dimensions

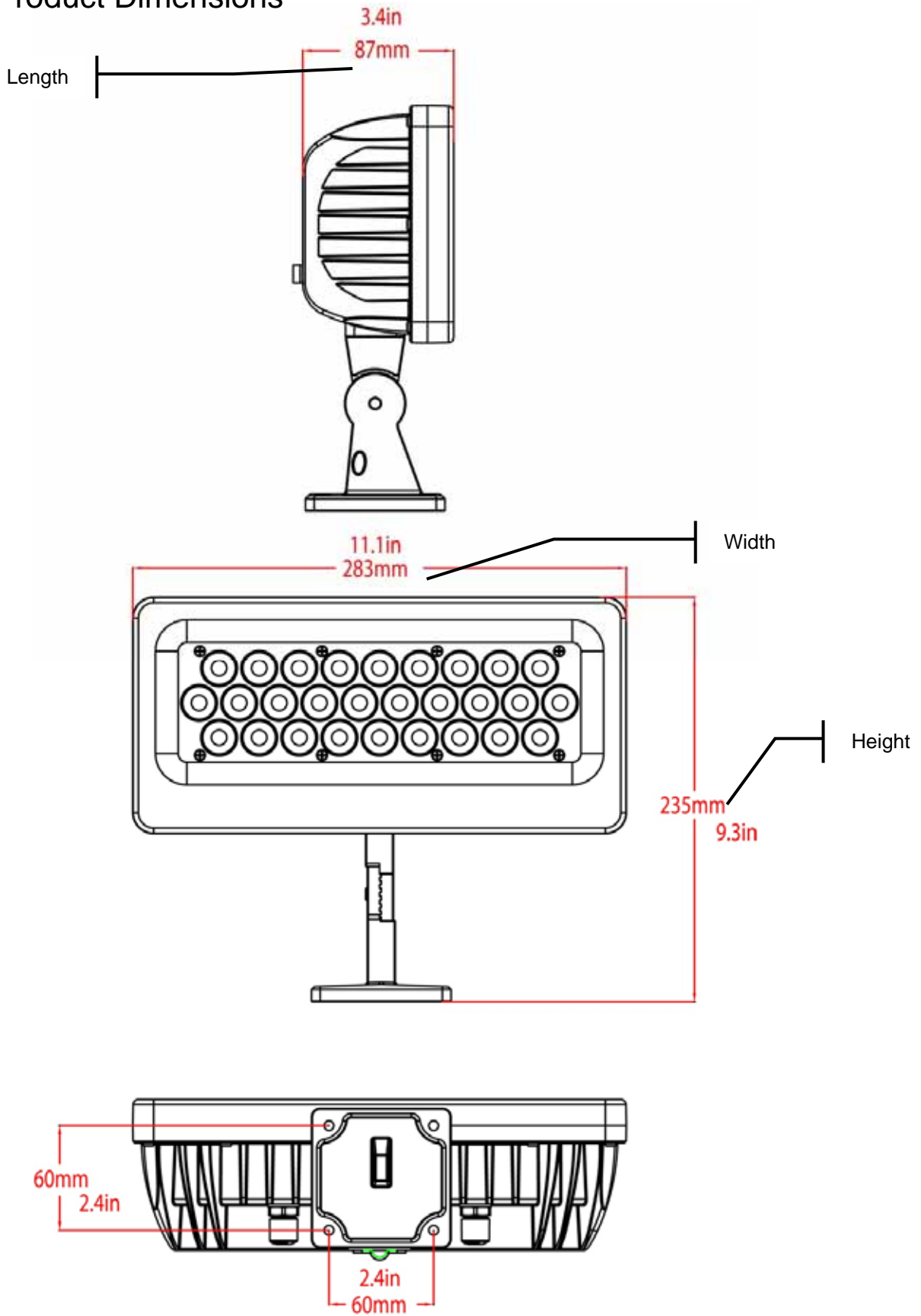

## 3. SETUP

### Fixture Linking

You will need a serial data link to run light shows of one or more fixtures using a DMX-512 controller or to run synchronized shows on two or more fixtures. The combined number of channels required by all the fixtures on a serial data link determines the number of fixtures the data link can support.

**Important:** Fixtures on a serial data link must be daisy chained in one single line. To comply with the EIA-485 standard no more than 32 devices should be connected on one data link. Connecting more than 32 fixtures on one serial data link without the use of a DMX optically-isolated splitter may result in deterioration of the digital DMX signal.

**Note!:** USITT recommends limiting the total length of the DMX cable (from the first fixture/controller to the last fixture) to 300 ~ 455 m (985 ~ 1,500 ft). The maximum recommended number of fixtures on a serial data link is 32 fixtures.

### Data Cabling

To link fixtures together you must obtain data cables. If you choose to create your own cable please use data-grade cables that can carry a high quality signal and are less prone to electromagnetic interference.

#### DMX Data Cable

Use a Belden© 9841 or equivalent cable which meets the specifications for EIA RS-485 applications. Standard microphone cables cannot transmit DMX data reliably over long distances. The cable will have the following characteristics:

*2-conductor twisted pair plus a shield  
 Maximum capacitance between conductors – 30 pF/ft.  
 Maximum capacitance between conductor and shield – 55 pF/ft.  
 Maximum resistance of 20 ohms / 1000 ft.  
 Nominal impedance 100 – 140 ohms*

#### Signal Distribution

Connect the bare-ended signal cable from the product to a signal distribution box as indicated below.

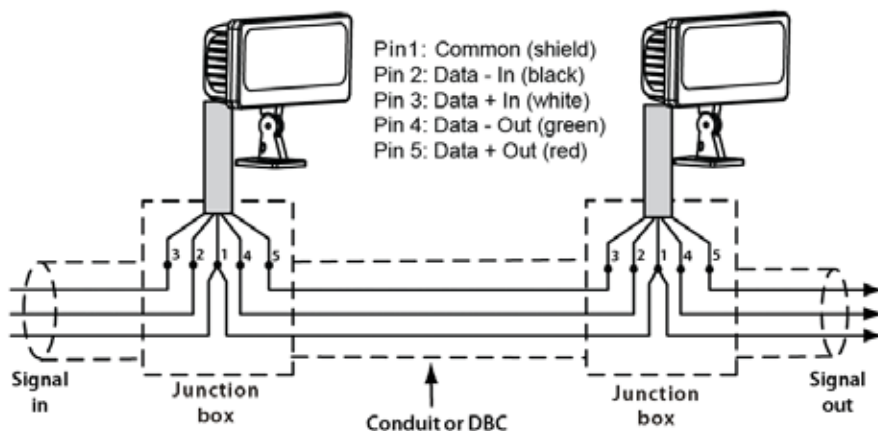

## Wiring diagram

DATA IN/OUT		
Ground		Pin 1 (shield)
Data input ( - )		Pin 2 (black)
Data input ( + )		Pin 3 (white)
Data output ( - )		Pin 4 (green)
Data output ( + )		Pin 5 (red)

POWER IN		
Ground	E	Green
Live	L	Black
Neutral	N	White

## Mounting

### Orientation

This fixture may be mounted in any safe position.

### Rigging

Mount the fixture, using the 4 mounting points.

- When selecting installation location, take into consideration programming adjustment(s) and routine maintenance.
- When mounting the fixture, be sure that the location can support the weight of the fixture.

## 4. OPERATING INSTRUCTIONS

### Menu Map (Ilumicode-remote addresser)

MAIN FUNCTION	SUB-FUNCTION SELECTION	INSTRUCTION
<b>DMX address</b>	001~512	Sets the DMX starting address
<b>Personality</b>	Remote	For use with optional controller (see website for more information)
	ARC 1	3-channel RGB color mixing
	ARC 1+D	4-channel RGB + dimmer
	ARC FULL	7-channel RGB + dimmer, Color Macro, Strobe
<b>Calibration</b>	<b>White</b> (1~11) Red Green Blue (0~255)	Edit white color of different color temperatures
	<b>RGB</b> Red Green Blue (0~255)	Modify RGB dim to White values
<b>Dimmer</b>	Off	No function
	Dim1	Select between 4 dimmer curves for the fixture
	Dim2	
	Dim3	
	Dim4	
<b>Static</b>	Red Green Blue Strobe (0~20 Hz) (0~255)	Combine the different attributes to create a static scene

### Operation

This fixture requires the Ilumicode remote addresser to change the starting address, change the personality, change the dimming curve, or to set the fixture to operate on a static program. Please see the below instructions for this process.

- 1) Plug the Ilumicode into the DMX in.
  - 2) Press the power button.
  - 3) Modify the settings as desired.
  - 4) Press the enter key after each setting modification.
  - 5) The fixture should light green when a setting has been successfully changed, and remain lit for 15 seconds.
- You must press **ENTER** after each setting modification in order to properly send the setting to the fixture
  - You may only modify a maximum of up to 20 fixtures at a time with the Ilumicode. However, each fixture that is attached will have the same identity. In order to have individual addressing, connect 1 fixture at a time.
  - The Ilumicode will automatically power off after being idle for 1 minute.

## DMX Channel Values

### ARC FULL

CHANNEL	VALUE	FUNCTION
1	000 ⇄ 255	<b>Dimmer</b> 0~100%
2	000 ⇄ 255	<b>Red</b> 0~100%
3	000 ⇄ 255	<b>Green</b> 0~100%
4	000 ⇄ 255	<b>Blue</b> 0~100%
5	000 ⇄ 010	<b>Color Macro</b> No function
	011 ⇄ 035	Red 100%/Green up/Blue 0%
	036 ⇄ 060	Red down/Green 100%/Blue 0%
	061 ⇄ 085	Red 0%/Green 100%/Blue up
	086 ⇄ 110	Red 0%/Green down/Blue 100%
	111 ⇄ 135	Red up/Green 0%/Blue 100%
	136 ⇄ 160	Red 100%/ Green 0%/Blue down
	161 ⇄ 185	Red 100%/Green up/ Blue up
	186 ⇄ 210	Red down/Green down/Blue 100%
	211 ⇄ 215	White 1: 3200K
	216 ⇄ 220	White 2: 3400K
	221 ⇄ 225	White 3: 4200K
	226 ⇄ 230	White 4: 4900K
	231 ⇄ 235	White 5: 5600K
236 ⇄ 240	White 6: 5900K	
241 ⇄ 245	White 7: 6500K	
246 ⇄ 250	White 8: 7200K	
251 ⇄ 255	White 9: 8000K	
6	000 ⇄ 004	<b>Strobe</b> No function
	005 ⇄ 255	Strobe (slow ~ fast)
7	000 ⇄ 009	<b>Dimming Speed</b> Off
	010 ⇄ 069	Speed 1 (fastest)
	070 ⇄ 129	Speed 2
	130 ⇄ 189	Speed 3
	190 ⇄ 255	Speed 4 (slowest)

## ARC 1

CHANNEL	VALUE	FUNCTION
1	000 ⇄ 255	<b>Red</b> 0~100%
2	000 ⇄ 255	<b>Green</b> 0~100%
3	000 ⇄ 255	<b>Blue</b> 0~100%

## ARC 1+D

CHANNEL	VALUE	FUNCTION
1	000 ⇄ 255	<b>Dimmer</b> 0~100%
2	000 ⇄ 255	<b>Red</b> 0~100%
3	000 ⇄ 255	<b>Green</b> 0~100%
4	000 ⇄ 255	<b>Blue</b> 0~100%

## Solid

CHANNEL	VALUE	FUNCTION
1	000 ⇄ 255	<b>Dimmer</b> 0~100%

---

## Contact Us

### World Wide

#### *General Information*

ILUMINARC®  
 5200 NW 108th Avenue  
 Sunrise, FL 33351  
 Voice: (954) 923-3680  
 Fax: (954) 929-5571  
 Email: [info@iluminarc.com](mailto:info@iluminarc.com)

#### World Wide Web

[www.ILUMINARC.com](http://www.ILUMINARC.com)

---

## 5. APPENDIX

### DMX Primer

There are 512 channels in a DMX-512 connection. Channels may be assigned in any manner. A fixture capable of receiving DMX 512 will require one or a number of sequential channels. The user must assign a starting address on the fixture that indicates the first channel reserved in the controller. There are many different types of DMX controllable fixtures and they all may vary in the total number of channels required. Choosing a start address should be planned in advance. Channels should never overlap. If they do, this will result in erratic operation of the fixtures whose starting address is set incorrectly. You can however, control multiple fixtures of the same type using the same starting address as long as the intended result is that of unison movement or operation. In other words, the fixtures will be slaved together and all respond exactly the same.

DMX fixtures are designed to receive data through a serial Daisy Chain. A Daisy Chain connection is where the DATA OUT of one fixture connects to the DATA IN of the next fixture. The order in which the fixtures are connected is not important and has no effect on how a controller communicates to each fixture. Use an order that provides for the easiest and most direct cabling. Connect fixtures using shielded two conductor twisted pair cable. The shield connection is pin 1, while pin 2 is Data Negative (S-) and pin 3 is Data positive (S+).

### Setting the Starting Address

This DMX mode enables the use of a universal DMX controller device. Each fixture requires a "start address" from 1 to 512. A fixture requiring one or more channels for control begins to read the data on the channel indicated by the start address. For example, a fixture that uses 6 DMX channels and was addressed to start on DMX channel 100, would read data from channels: 100, 101, 102, 103, 104, and 105. Choose start addresses so that the channels used do not overlap, and note the start address selected for future reference.

If this is your first time addressing a fixture using the DMX-512 control protocol, we suggest jumping to the Appendix Section and reading the heading "DMX Primer". It contains very useful information that will help you understand its use.

---

## General Maintenance

To maintain optimum performance and minimize wear, fixtures should be cleaned frequently. Usage and environment are contributing factors in determining frequency. As a general rule, fixtures should be cleaned at least twice a month. Dust build up reduces light output performance and can cause overheating. This can lead to reduced LED life and increased mechanical wear. Be sure to power off fixture before conducting maintenance.

Use a soft brush to remove dust collected on external surface. Clean all glass when the fixture is cold with a mild solution of glass cleaner or Isopropyl Alcohol and a soft lint free cotton cloth or lens tissue. Apply solution to the cloth or tissue and drag dirt and grime to the outside of the lens. Gently polish optical surfaces until they are free of haze and lint.

The cleaning of external optical lenses and/or mirrors must be carried out periodically to optimize light output. Cleaning frequency depends on the environment in which the fixture operates: damp, smoky, or particularly dirty surroundings can cause greater accumulation of dirt on the unit's optics. Clean with soft cloth using normal glass cleaning fluid. Always dry the parts carefully. Clean the external optics at least every 20 days.

## Returns Procedure

Returned merchandise must be sent prepaid and in the original packing, call tags will not be issued. Package must be clearly labeled with a Return Merchandise Authorization Number (RMA #). Products returned without an RMA # will be refused. Call ILUMINARC™ and request RMA # prior to shipping the fixture. Be prepared to provide the model number, serial number and a brief description of the cause for the return. Be sure to properly pack fixture, any shipping damage resulting from inadequate packaging is the customer's responsibility. ILUMINARC™ reserves the right to use its own discretion to repair or replace product(s). As a suggestion, proper UPS packing or double-boxing is always a safe method to use.

**Note:** If you are given an RMA #, please include the following information on a piece of paper inside the box:

- 1) Your name
- 2) Your address
- 3) Your phone number
- 4) The RMA #
- 5) A brief description of the symptoms

## Claims

Damage incurred in shipping is the responsibility of the shipper; therefore the damage must be reported to the carrier upon receipt of merchandise. It is the customer's responsibility to notify and submit claims with the shipper in the event that a fixture is damaged due to shipping. Any other claim for items such as missing component/part, damage not related to shipping, and concealed damage, must be made within seven (7) days of receiving merchandise.

## Technical Specifications

### WEIGHT & DIMENSIONS

Length..... 11.1 in (283 mm)  
 Width..... 3.4 in (87 mm)  
 Height ..... 9.3 in (235 mm)  
 Weight..... 6.5 lbs (3 kg)

### LIGHT SOURCE

LED 28 x 1 W, 350 mA (10 red, 9 green, 9 blue), 50,000 hrs

### ELECTRICAL SPECIFICATIONS

Autoswitching internal power supply..... 100~240 VAC, 50/60 Hz  
 Power consumption @ 115 V, 60 Hz..... 33 W (0.5 A)  
 Power factor @ 115 V, 60 Hz ..... 0.55  
 Power consumption @ 230 V, 60 Hz..... 36 W (0.31 A)  
 Power factor @ 230 V, 60 Hz ..... 0.53

### EXTENDED INFORMATION

Construction..... Cast aluminum

### REMOTE ADDRESSER

Ilumicode ..... 44444001

### ORDERING DETAILS

Ilumipanel 28 IP Optic 15 RGB (gray housing)..... 13028002  
 Ilumipanel 28 IP Optic 30 RGB (gray housing)..... 13028001



**LED Life:** ILUMINARC™ rates LED lifetime based on lumen depreciation of 70% of the original output, with data provided by the manufacturer of the LED. Data from the manufacturer of the LED are not independently verified or measured by ILUMINARC™. When the fixture is operating in optimal environmental conditions, the LED lifetime is rated to be 50,000 to 70,000 hours by the LED manufacturer.

**LED Binning:** LED manufacturers sort LEDs into "bins", based on variances in color, output intensity and the frequency at which the semiconductor operates. ILUMINARC™ strives to hold its LED manufacturers to the highest standards of binning to optimize consistency in output from fixture to fixture. However, the availability of a single bin cannot be guaranteed. With that in mind, ILUMINARC™ has developed a rigorous control system to seek the best achievable consistency in color and output.

**Color Rendering Index (CRI):** CRI is an industry standard method to compare properties of different types of light sources. There are known limitations and inconsistencies related to CRI. Results may vary depending on the environmental factors involved. For this reason, the US Department of Energy (DOE) states that CRI should be considered as one point of reference among others in evaluating white LED products and systems.

**The following is an excerpt of recommendations from the DOE:**

1. Identify the visual tasks to be performed under the light source. If color fidelity under different light sources is critically important (for example in a space where color or fabric comparisons are made under both daylight and electric lighting), CRI values may be a useful metric for rating LED products.
2. CRI may be compared only for light sources of equal CCT. This applies to all light sources, not only to LEDs. Also, differences in CRI values of less than five points are not significant, e.g., light sources with 80 and 84 CRI are essentially the same.
3. If color appearance is more important than color fidelity, do not exclude white light LEDs solely on the basis of relatively low CRI values. Some LED products with CRIs as low as 25 still produce visually pleasing white light.
4. Evaluate LED systems in person and, if possible, on-site when color fidelity or color appearance are important issues.

**Source: DOE publication: PNNL-SA-56891, January 2008**